The Role of Models in Physics Instruction

Eugenia Etkina, Aaron Warren, and Michael Gentile, Rutgers University, New Brunswick, NJ

The word *modeling* is becoming more and more common in physics, chemistry, and general science instruction. In physics, students learn models of the solar system, light, and atom. In biology courses they encounter models of joints, the circulatory system, and metabolic processes. The benefits of engaging students in model building are described in the literature.¹⁻⁵ “Modeling instruction” is an example of a whole curriculum based on the idea of modeling.⁶ However, in a traditional physics class students do not have a clear understanding of what the word *model* means, and thus do not appreciate the role of this notion in physics.⁷⁻⁹ Physics teachers also have difficulties defining this word.^{10,11} The purposes of this paper are (a) to reexamine the word *model* as it is used in science, and (b) to suggest several types of tasks that engage students in the construction of models in a regular-format introductory physics course.

What Is a Model?

The modeling approach in physics began with Rene Descartes. He was the first to propose that the mental constructs of a scientist about the world were not to be considered “postulates representing his own beliefs but as useful models from which one could deduce consequences in agreement with observations.”¹²

In physics education research the word *model* is associated with David Hestenes and his colleagues, who advocated the use of models in physics instruction more than 20 years ago. He defined a model in the following way: “A model is a surrogate object, a conceptual representation of a real thing. The models

in physics are mathematical models, which is to say that physical properties are represented by quantitative variables in the models.”¹

In general, physicists share several common ideas about models:

- a) a model is a *simplified version* of an object or process under study; a scientist creating the model decides what features to neglect;
- b) a model can be *descriptive* or *explanatory*; explanatory models are based on analogies—relating the object or process to a more familiar object or process;
- c) a model needs to have *predictive* power;
- d) a model’s predictive power has *limitations*.¹³

Mastering these ideas is difficult. How does one know what to neglect while simplifying an object or a process? Can the same object or process be modeled differently in different situations? How does one make a decision whether a particular model is appropriate? How can one use models to make predictions?

In the following section we explore the meaning of the word *model* at a deeper level, which will ultimately allow us to devise tasks for students that address the questions raised in the previous paragraph.

Classifying Models

As discussed above, scientists use models or *simplifications* to describe and explain observed physical phenomena and to predict the outcomes of new phenomena. We suggest that when simplifying a phenomenon to make a model, we simplify 1) objects, 2) interac-

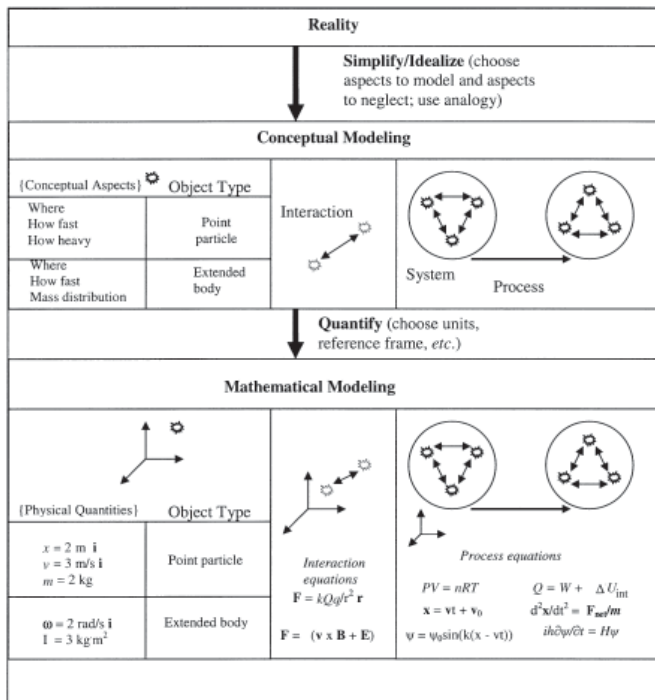

Fig. 1. We can model nature by focusing on an object, an interaction, a system, or a process. Quantifiable models include mathematical expressions such as interaction equations, state equations, and causal equations.

tions between objects, 3) systems of objects together with their interactions, and/or 4) processes (Fig. 1). This classification gives us four types of models.

- 1. Models of objects:** When we choose to investigate a physical phenomenon, we first identify the objects involved. We then decide how we will simplify these objects. For example, we can model the same car as a point particle, or as an extended rigid body, or as multiple extended rigid bodies.
- 2. Models of interactions:** When there are multiple objects involved, we need to consider interactions between those objects. We make decisions to neglect some interactions and take others into account. We can model interactions quantitatively in terms of the strength and the direction of a force or a field, or the magnitude and the sign of a potential energy. When we quantify this picture we get some mathematical expressions that we call interaction equations. An example of an interaction equation is Coulomb's law.
- 3. Models of systems:** By combining the models of objects and interactions for a physical system, we get a model of the system. For example, if we sim-

plify a gas as many point particles that interact with the walls of their container via elastic collisions, we have a model of a system known as an ideal gas.

4(a). Models of processes (qualitative): Due to the interactions between the objects in a system or with objects outside a system, the system may change in some manner. We will refer to a model that describes the changes in a system as a process model. For example, we can explain qualitatively a thermodynamic process involving a gas in a container with a movable piston using the model of an ideal gas and considering its interactions with the piston.

4(b). Models of processes (quantitative): When we quantify our models of systems and processes, we get mathematical expressions that we call *state equations* and *causal equations*. A state equation describes how one or more properties of a system vary in relation to each other, but the cause of the change is unspecified. A causal equation, however, describes how the properties of a system are affected by its interactions with the environment.

A *state equation* is a mathematical expression in which each quantity corresponds to various properties of a single system. For instance, $x = x_0 + v_x t$ is a state equation, a model of a process involving a point particle. Another example is the ideal gas law, a model of a process involving an ideal gas. Each quantity in the equation corresponds to a property of a gas (which is a system of point particles). On the other hand, a *causal equation* is any mathematical expression that includes quantities that correspond to physical interactions between a system and its environment. For example, in the first law of thermodynamics heating and work cause changes in the internal energy of a system. Other examples of causal equations are the impulse-momentum equation, the work-energy equation, and Schrödinger's equation. The most fundamental causal equations are based on symmetries.¹⁴

Each of these models can be represented in many ways, including words, mathematical functions, graphs, pictures, and model-specific representations such as motion diagrams, free-body diagrams, energy bar charts, ray diagrams, and so forth. Students need to learn how to use these representations to solve specific problems. Much has been written about the importance of representations in physics instruction and

successful instructional strategies.¹⁵⁻¹⁷

Students often engage in modeling during our classes but are unaware of it. In the section below we suggest several types of tasks that make this process explicit and encourage students to consciously engage in and reflect on modeling.

Engaging Students in Making and Testing Models

In physics education, modeling of phenomena for investigations and problem solving has been done mostly by Hestenes and his colleagues.^{1-3, 6} Their approach assumes consistent use of special vernacular, representations, and problem-solving strategies during instruction. We suggest that tasks engaging students in deliberate modeling of real situations can be used in any physics course, while students are engaged in problem solving or laboratory exercises. We describe examples of activities to help students practice model construction, evaluation, and revision of models. The tasks are grouped under three categories: the *types of models* identified in the “Classifying models” section (models of objects, interactions, systems, and processes), *the purposes* of modeling as identified in the section “What Is a Model” (describing, explaining, and predicting), and *the limitations* of the models. The wording of the tasks follows the recommendations of Heller and colleagues.¹⁸

Different Types of Models

1) Choosing a model of an object

- A 70-m long train leaves a station accelerating at 2 m/s^2 . You are at the platform entrance 30 m from the tracks. To determine if you can catch the train, would you model the train as a point particle or as a rigid object with a definite length? Explain.
- The same train travels for 10 hours and covers 630 miles. To determine the train’s average speed, would you model the train as a point particle or as a rigid object with a definite length? Explain

2) Choosing a model of an interaction

You have been hired as a consultant for NASA and the following task is given to you: You are in charge of a group whose job is to design a computer program that can quickly calculate the energy of an Earth-rocket system. The rocket will travel from

the Earth’s surface to an orbit high above the Earth. You know that the gravitational potential energy of a system consisting of two objects of masses M and m (when the smaller object is outside the more massive object) is $U = -GMm/r$. To make your computer program as fast as possible, though, you want to know when it is OK to treat the gravitational potential energy of the system as $U = mgh$.

- Where do we set $U = 0$ when we use $U = mgh$?
- Using your answer to part (a), show that we can use $U = -GMm/r$ to derive $U = mgh$. [Hint: $1/(R + h) \approx (1/R) - (h/R^2)$ if $h \ll R$].
- Based on the approximation used in part (b), when do you think it is reasonable to use $U = mgh$?

3) Choosing a model of a system

You are an assistant for the physics labs. You just found a resistor in your desk drawer and are curious about its resistance. You have a battery, some connecting wires, an ammeter, and a voltmeter. You decide to measure the voltage across the resistor and divide it by the current through the resistor. You build a circuit as shown below (Fig. 2a) and then realize that there is another way to do it (Fig. 2b).

What modeling assumptions about objects and

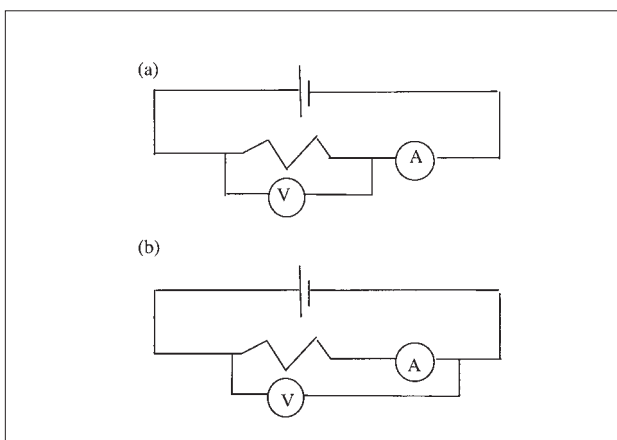

Fig. 2. Using the reading of the ammeter and voltmeter to calculate the resistance of the resistor leads to different results for different circuit arrangements.

processes in the circuit do you need to make to go with the first circuit or with the second? What information about the elements of the circuit do you need to have in order to decide which method (a or b) is applicable to the circuit? (Hint: Remember that both measuring devices have internal resistance.)

4) Choosing a model of a process

State equations

Given a rigid 0.50 m^3 container with 4.46 mol of air inside, and an initial temperature of 500 K , you measure a pressure of 37.06 kPa . You then cool it to a temperature of 133 K while compressing the gas to a volume of 0.10 m^3 . The pressure of the gas is now measured to be 49.10 kPa . Two possible models of the gas are the ideal gas model and Van der Waal's model. Determine how consistent each of these models are with the reported measurements ($a = 0.1358 \text{ J}\cdot\text{m}^3/\text{mol}^2$, $b = 3.64 \times 10^{-5} \text{ m}^3/\text{mol}$ for air). If one model is more accurate for a certain measurement, propose an explanation for why this is the case.

Causal equations

You are analyzing a video of a falling beach ball ($m = 500\text{g}$, $R = 20 \text{ cm}$) by viewing it frame by frame. You find that the acceleration of the ball is constant and equal to 8.8 m/s^2 . You decide to analyze the situation by modeling the interactions of the ball with the Earth and air. What modeling assumptions about the interactions and processes do you need to make to explain the acceleration of the ball?

Purposes/Uses of Models

5) Using models to describe phenomena

You bought a motorized toy car for your little sister. How can you find out which model describes the motion of the car best: the model of motion with constant speed, constant acceleration, or changing acceleration?

6) Using models to explain phenomena

You have a cart on an air track attached by a string that passes over a pulley down to a hanging object [see Fig. 3(a)].

You push it abruptly toward the left. The cart moves to the left, slows down, stops, and starts moving to the right with increasing speed. The graph for the cart's acceleration versus time is shown in Fig 3(b). When you repeat the same experiment with a cart on a regular track, the acceleration-versus-time graph looks different [see Fig. 3(c)].

Identify models of objects, interactions, systems, and processes that can help you to explain each graph

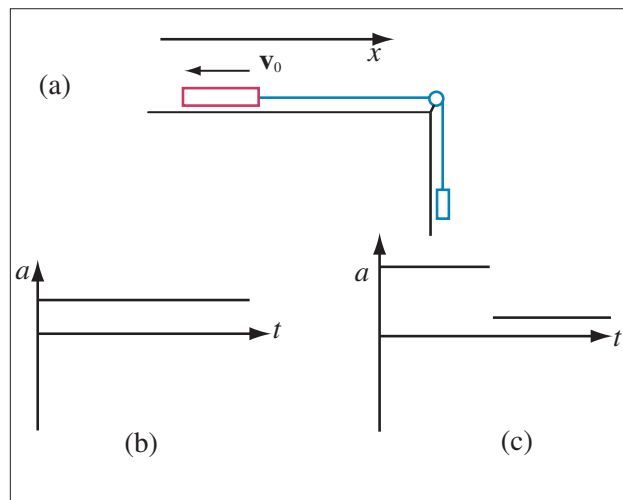

Fig. 3. (a) A cart on the air track connected by a string that passes over a pulley to a hanging object was abruptly pushed in the negative direction and let go. **(b)** The acceleration-versus-time graph for the cart. **(c)** The acceleration-versus-time graph for the same cart when the experiment was repeated on a regular track.

and discrepancies between them.

7) Using models to predict new phenomena

A helium-filled balloon is attached to a light string and placed inside a box made of transparent plastic. The box has wheels on the bottom that allow it to roll. Explain why the balloon and string are vertical.¹⁹ What models of objects and interactions did you use? Predict what will happen to the thread and the balloon if you abruptly push the box to the left. To make the prediction, explain what models of objects and interactions you will include in your system and how you will model any processes that occur. Then observe the experiment. If your prediction does not match the result, revise your model in order to get a new prediction that does match the result.

Model Limitations

8) Limitations of models objects, interactions and processes

Your friend's lab group has to figure out the specific heat of a 0.50-kg rock. They plan to heat the rock by letting it sit in a 200°C oven for five minutes. Then they will put the rock in a thermos filled with 200 g of ice (measured with a dietary scale), close the thermos, and wait another five minutes. After doing all

this, they open the thermos and find that the ice has completely melted. They measure the final temperature of the rock by measuring the final temperature of the melted ice water, which is 20°C. They calculate the specific heat of the rock as follows:

$$m_{\text{ice}}L_f + m_{\text{ice}}C_{\text{water}}\Delta T_{\text{ice water}} + m_{\text{rock}}C_{\text{rock}}\Delta T_{\text{rock}} = 0$$

$$C_{\text{rock}} = -[(0.2 \text{ kg})(33.5 \times 10^4 \text{ J/kg}) + (0.2 \text{ kg}) \times$$

$$4186 \text{ J/(kg}\cdot\text{K)} \times 20^\circ\text{C}] / [0.50 \text{ kg} \times (-180^\circ\text{C})] =$$

$$930 \text{ J/(kg K)} .$$

Identify all the modeling assumptions your friend's group has made about the objects, interactions, systems, and processes, and evaluate whether or not each assumption should be accepted.

Conclusion

Choosing a productive model to describe or explain a phenomenon under study is a routine part of the work of scientists but a rare exercise for our students. Students have difficulties understanding the meaning of the word *model* and using it to analyze physical phenomena and solve problems. We hope that by creating and using tasks similar to the ones shown here students can become more proficient at modeling. To help students you can engage them in “meta-modeling”—reflection on the purposes and outcomes of the modeling process. We encourage instructors to develop their own tasks like those shown above, and to incorporate them into their curricula. Solutions to the problems presented in the paper and more tasks are available at <http://paer.rutgers.edu/ScientificAbilities/ModelingTasks/default.aspx>.

Acknowledgments

We thank Michael Lawrence and Suzanne Brahmia for providing suggestions for the tasks, and David Brookes and Alan Van Heuvelen for helping with the preparation of the manuscript. We also thank an anonymous reviewer for helpful comments and suggestions. The project was supported in part by NSF grant DUE 024178.

References

1. D. Hestenes, “Toward a modeling theory of physics instruction,” *Am. J. Phys.* **55**, 440–454 (May 1987).
2. I. Halloun, “Schematic modeling for meaningful understanding of physics,” *J. Res. Sci. Teach.* **33**, 1019–1041 (1996).
3. I. Halloun, “Schematic concepts for schematic models of the real world: The Newtonian concept of force,” *Sci. Educ.* **82**, 239 (April 1998).
4. I.M. Greca and M.A. Moreira, “Mental, physical, and mathematical models in the teaching and learning of physics,” *Sci. Educ.* **86**, 106 (Jan. 2002).
5. A.G. Harrison and D.F. Treagust, “Learning about atoms, molecules, and chemical bonds: A case study of multiple-model use in grade 11 chemistry,” *Sci. Educ.* **84**, 352–381 (May 2000).
6. M. Wells, D. Hestenes, and G. Swackhamer, “A modeling method for high school physics instruction,” *Am. J. Phys.* **63**, 606–619 (July 1995).
7. L. Grosslight, C. Unger, and E. Jay, “Understanding models and their use in science: Conceptions of middle and high school students and experts,” *J. Res. Sci. Teach.* **28**, 799–822 (1991).
8. D.F. Treagust, G. Chittleborough, and T.L. Mamiala, “Students’ understanding of the role of scientific models in learning science,” *Int. J. Sci. Educ.* **24**, 357 (April 2002).
9. J. Ryder and J. Leach, “Interpreting experimental data: The views of upper secondary school and university science students,” *Int. J. Sci. Educ.* **22**, 1069 (Oct. 2000).
10. R.S. Justi and J.K. Gilbert, “Modelling, teachers views on the nature of modelling, and implications for the education of modellers,” *Int. J. Sci. Educ.* **24**, 369 (April 2002).
11. Private communication with Jane Jackson.
12. G. Holton and S.G. Brush, *Physics, the Human Adventure: From Copernicus to Einstein and Beyond*, 3rd ed. (Rutgers Univ. Press, New Brunswick, NJ, 2001), p. 526.
13. E. Etkina, T. Matilsky, and M. Lawrence, “What can we learn from pushing to the edge? Rutgers Astrophysics Institute motivates talented high school students,” *J. Res. Sci. Teach.* **40**, 958–985 (2003).
14. C.T. Hill and L.M. Lederman, “Teaching symmetry in the introductory physics curriculum,” *Phys. Teach.* **38**, 348 (Sept. 2000).
15. A. Van Heuvelen, “Learning to think like a physicist: A review of research-based instructional strategies,” *Am. J. of Phys.* **59**, 891–897 (Oct. 1991).

16. J.R. Frederiksen, B.Y. White, and J. Gutwill, "Dynamic mental models in learning science: The importance of constructing derivational linkages among models," *J. Res. Sci. Teach.* **36**, 809–836 (1999).
17. J.L. Lemke, "Teaching all the languages of science: Words, symbols, images, and actions," <http://www-personal.umich.edu/~jaylemke/papers/barcelon.htm>.
18. Students engage in similar activities while solving context-rich problems as in P. Heller, R. Keith, and S. Anderson, "Teaching problem solving through cooperative grouping Part 1," *Am. J. Phys.* **60**, 627–636 (July 1992).
19. Videos for modeling tasks and other videotaped experiments can be found at <http://paer.rutgers.edu/pt3>. The video of this experiment can be found at <http://paer.rutgers.edu/PT3/experiment.php?topicid=13&exptid=121>.

PACS codes: 01.40Gb, 01.55

Eugenia Etkina is an associate professor of science education at Rutgers University. She works with pre- and in-service physics teachers and with colleagues in physics who are reforming undergraduate physics courses.

**Graduate School of Education, Rutgers University,
10 Seminary Place, New Brunswick, NJ 08901-1183;
etkina@rci.rutgers.edu**

Aaron Warren is a graduate student in the Department of Physics and Astronomy working on his Ph.D in physics education research.

**Department of Physics and Astronomy, Rutgers
University, 136 Frelinghuysen Road, Piscataway, NJ
08854; aawarren@physics.rutgers.edu**

Michael Gentile is an instructor in the Department of Physics and Astronomy.

**Department of Physics and Astronomy, Rutgers
University, 136 Frelinghuysen Road, Piscataway, NJ
08854; mgentile@physics.rutgers.edu**